

Vintage Electric Staplers

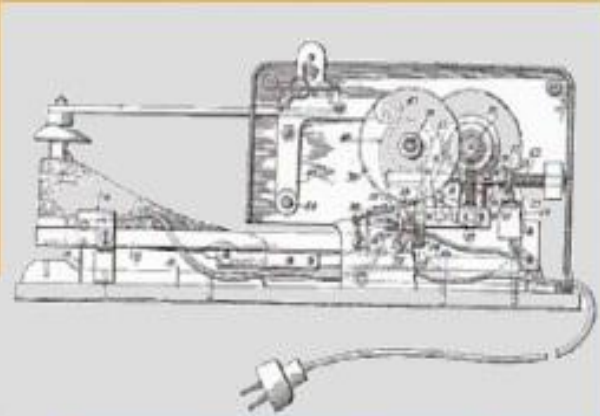

*from the archives of
Curtis Scaglione*



Vintage Electric Staplers

By Curtis Scaglione

Spend a little time looking up electric staplers and see what you find. Don't be at all surprised to find - Nothing. This is a subject that has not kindled the imagination of a single writer or historian. There will not be a special on the History Channel and it is highly unlikely one will not show up on the Antique Road Show. In fact, the real reason, this writer is tackling the subject, is because it has never been covered and should be if we are going to recognize this machine as a vintage fastener.

History will tell us that the electric motor was invented in the 19th century, but we will not concern ourselves with specifics, because there are many types and styles of motors. Used with actuators, you can pretty much apply motion to just about anything you want to be "electric".

The first electric typewriters were invented around 1899 by Charles Blickensderfer who did just that. He added the motor and actuator to existing patents and produced the first electric typewriter.

Some fastener historians will tell you that the electric stapler came to be in the 1950's, and that is all that is written on the subject as well. "The electric stapler came to be in the 1950's."

Early examples pop up every now and again. Acme, Boston Wire Stitcher, and Swingline appeared to be the leaders in the field and judging from the number of examples still out there, they most have done well for themselves. But, is for sure, other companies worked their magic and produced electric staplers.

ACME STAPLE COMPANY

To date, the Acme Stapler pictured below appears to be one of the oldest examples uncovered. Even So, Acme maintained its inventory for years, producing the same fasteners for decades. Therefore, until more information is provided, one can only assume.

This heavy duty or floor model clearly is electric but appears to be nothing more than an actuator connected to an existing model. The stapler is electric, but only in the most basic context.

Acme continually manufactured fasteners based on older patents. This example may be from the 1930's to early 1940's.



(Acme Floor Model)

BATES MANUFACTURING COMPANY

The stapler is a Bates H-30, which are still easily found today.

The motor that powers the actuator is a 2.2 amp, 1/15 horsepower Bodine electric motor and this is coupled through a solenoid clutch actuator.

To operate it, one has to turn on the main switch, then hold down the safety switch (which starts the motor whirring), then guide the paper under the stapler. This actuates the clutch solenoid, and with this, your papers are stapled.

The stapler takes standard staples therefore, 30 or 40 sheets of paper may be the maximum.

The base of this electric stapler is painted a light grey, which was common with office machine of the early 1950's period.





The stapler found in this example is the Bates H-30 a machine that was acquired when Bates acquired the Consolidated Wire Product Company of New York who produced the Mercury Sr. and Mercury Jr.

Nov. 8, 1949

S. LEBER ET AL
STAPLING APPARATUS

2,487,565

Filed Nov. 27, 1946

2 Sheets-Sheet 1

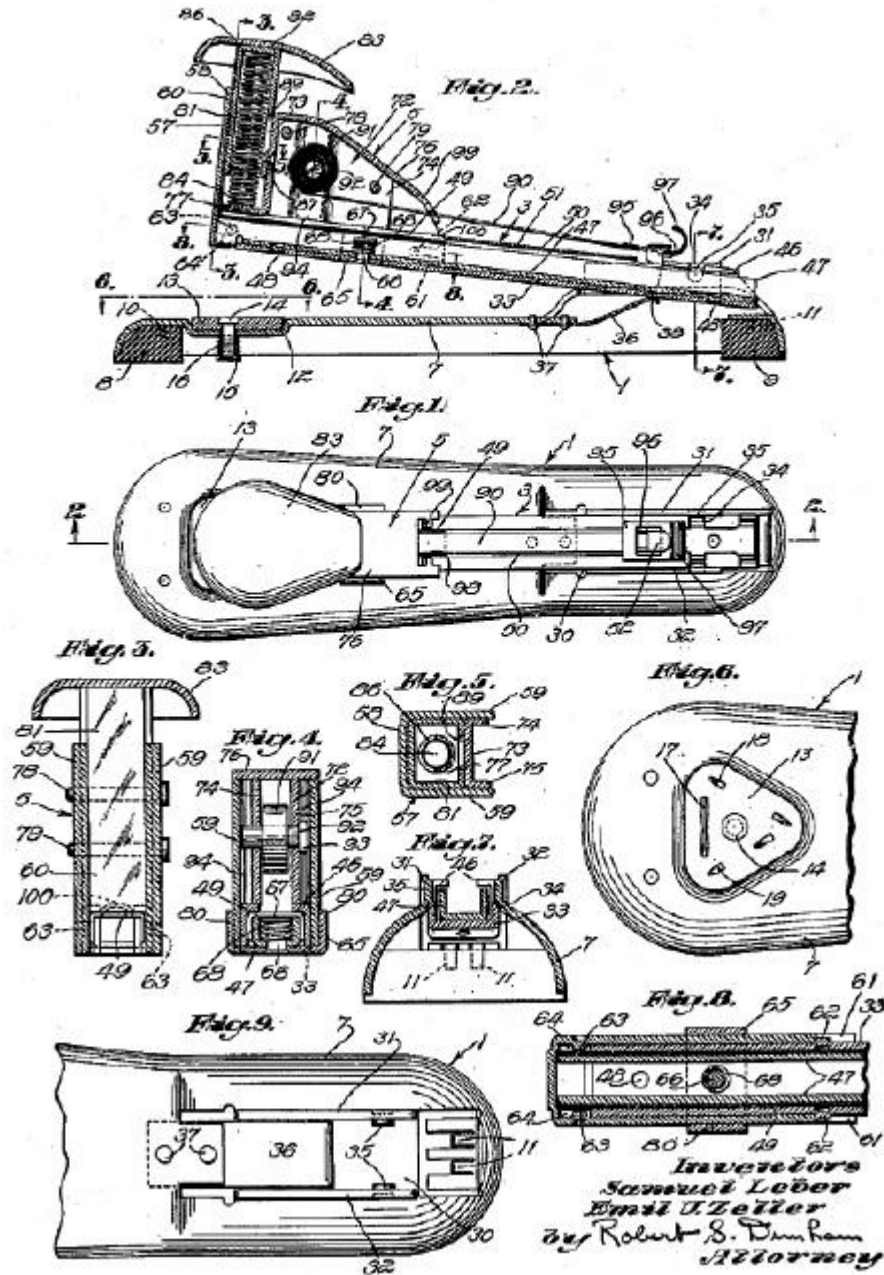

Researching patents have provided a likely find. Patent Number 2,643,307 Was granted to John J. Geel on June 23, 1953 for his invention of an electric Switch Actuator for an electric stapler. Geel assigned this invention to Francis E. Shreve of Charlotte, N.C.

June 23, 1953

J. J. GEEL

2,643,307

ELECTRIC SWITCH ACTUATOR

Filed Aug. 16, 1951

2 Sheets-Sheet 1

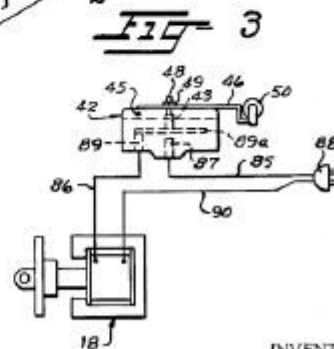
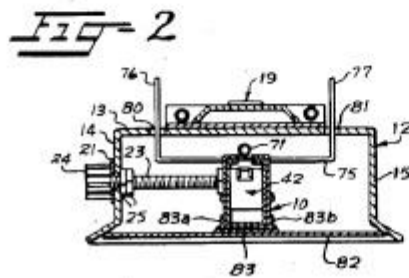
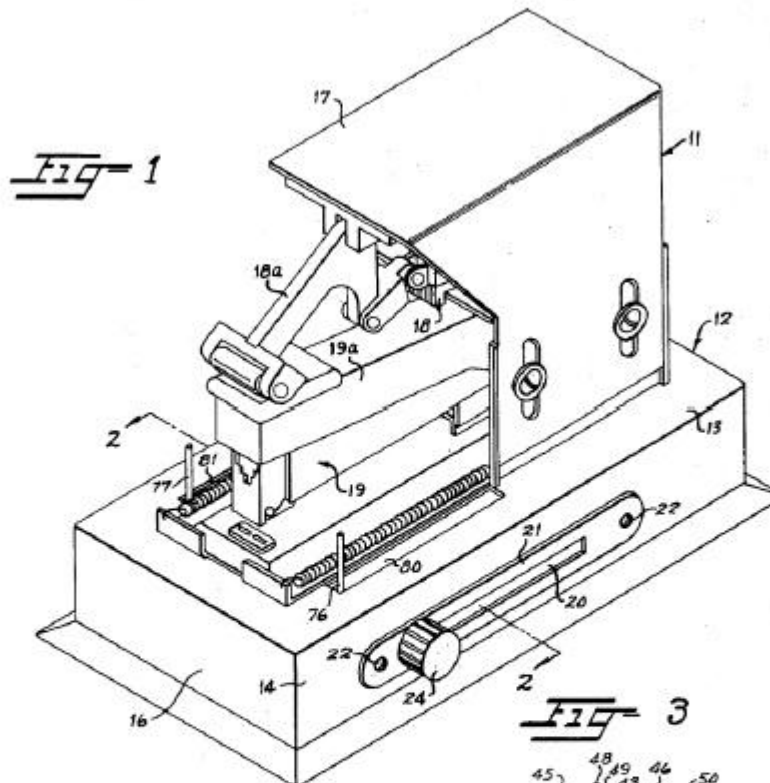

INVENTOR:
JOHN J. GEEL.

BY

Eaton & Bell

ATTORNEYS.

Patent Number 2,656,537 Was granted to John J. Geel as well, on October 27, 1953 for his invention of an electrically Operable Stapler Actuator . Again, Geel assigned this invention to Francis E. Shreve.

Oct. 27, 1953

J. J. GEEL

2,656,537

ELECTRICALLY OPERABLE STAPLER ACTUATOR

Filed Oct. 11, 1950

3 Sheets-Sheet 3

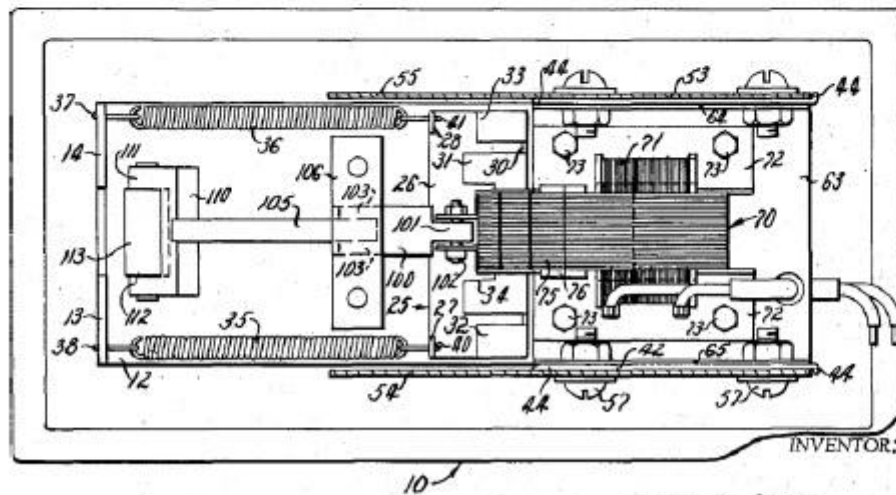
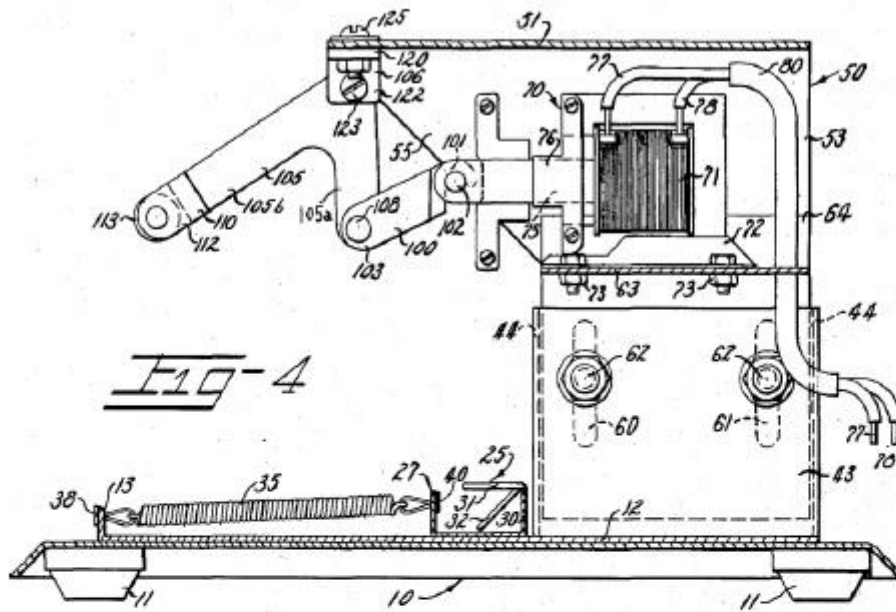

FIG-5

JOHN J. GEEL.
BY Eaton + Bell

INVENTOR:

ATTORNEY

Bodine, the maker of the motor on this example has a long history of automating machine previously considered manual. The following information is provided from their web site.

Bodine Electric Company History

Postwar Years

The end of World War II marked the beginning of an automated America. People had money to spend, goods that were scarce became plentiful, and people were fascinated by new gadgets and machines.

The most popular new product of the late 1940s and early 1950s was, of course, the television set.

Although people were skeptical at first, television revolutionized entertainment. Entire families crowded around the TV to see Milton Berle, I Love Lucy, and Ed Sullivan. The fare wasn't always what it might have been, but it was fun.

Not surprisingly, as television and other machines and appliances became part of everyday life, commercial electrical energy use increased dramatically: 333% between 1940 and 1954. Bodine was ready. Much of the technology the company developed for the war was



Continuous Service Induction Motors
Single Phase—Shaded Pole Start



applied to peacetime uses. The "KLI-2" series was one of several postwar products. These low-inertia motors were designed for quick response from a limited power supply, and were particularly valuable in electronically controlled instruments like chart recorders and electrocardiographs. The "NCH" line, designed for magnetic tape recorders, was also important in the early 1950s.

Bodine expanded with the office equipment industry after the war. One of the most significant introductions was the "K-4" motor, used in the first Royal electric typewriter. Again, Bodine provided a motor that eliminated problems manufacturers had experienced with other designs. The "K-4" series was quieter, and it gave off no radio interference to affect neighboring machines. Bodine also supplied motors for calculators, duplicating equipment, and adding and mailroom machines.

Perhaps the most exciting development in office equipment came in the late 1950s when the then Haloid Corporation approached Bodine for a motor for a new kind of copying machine. Bodine supplied the motor for the first of what was to be called the "Xerox®" machine, and continues to make special motors for many of the large copier manufacturers.

BOSTITCH

Invented by Charles E. Shank and Nathan Smith, this model was to be known as the Model 4. As of this writing, this is one of the oldest office model electric staplers found.

The patent was applied for on December 17, 1936 and on July 27, 1937 it was approved. Patent number 2,088,350 was assigned to this device.

In contacting Stanley Bosch, it was determined that they have no information on this electric stapler which leaves this writer to establish a date. Granted, it is not definitive but at least we as collectors will have more information to work with. Based on the patent of the electric stapler and of the stapler itself, it is believed this machine was developed during the early 1940s.



The stapler used for the early electric fastener was the star of the Boston Wire Stitcher's fleet. This stapler was produced for many years and had a reputation of lasting a life time.

April 14, 1936.

A. H. MAYNARD

2,037,334

PASTENER APPLYING IMPLEMENT

Filed Nov. 2, 1933

4 Sheets-Sheet 1

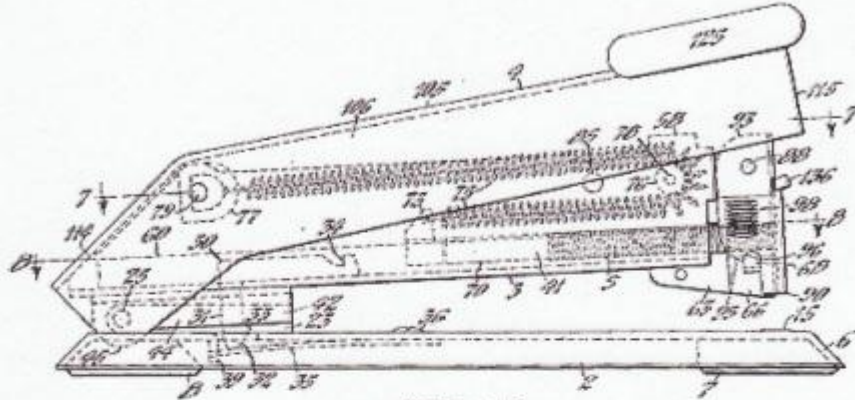

Fig. 1.

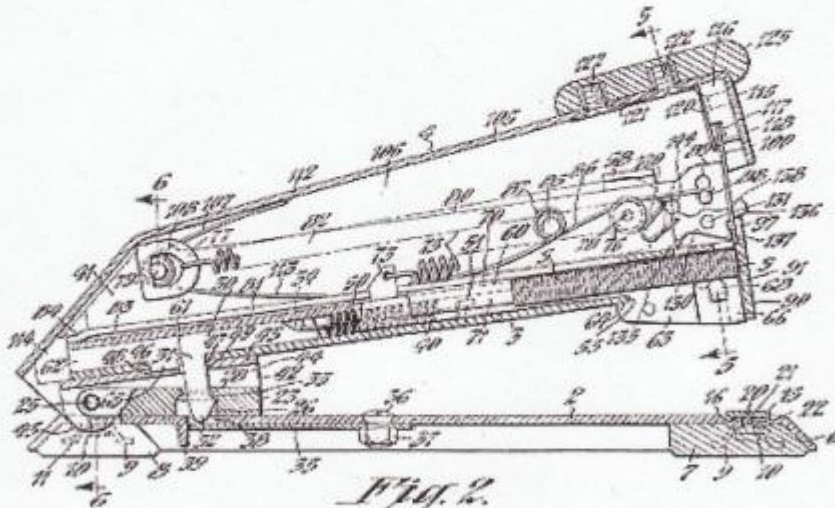

Fig. 2.

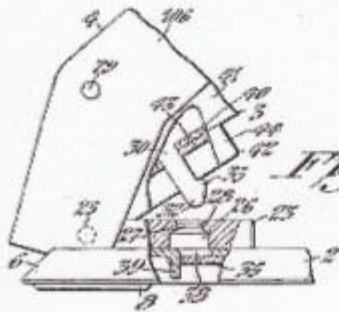

Fig. 3.

Inventor:
Arthur H. Maynard
By
Messrs. [Signature]
Attorneys.

July 27, 1937.

C. E. SHANKS ET AL

2,088,350

ELECTRIC POWER UNIT FOR FASTENER APPLYING DEVICES

Filed Dec. 17, 1935

3 Sheets-Sheet 1

Fig. 1.

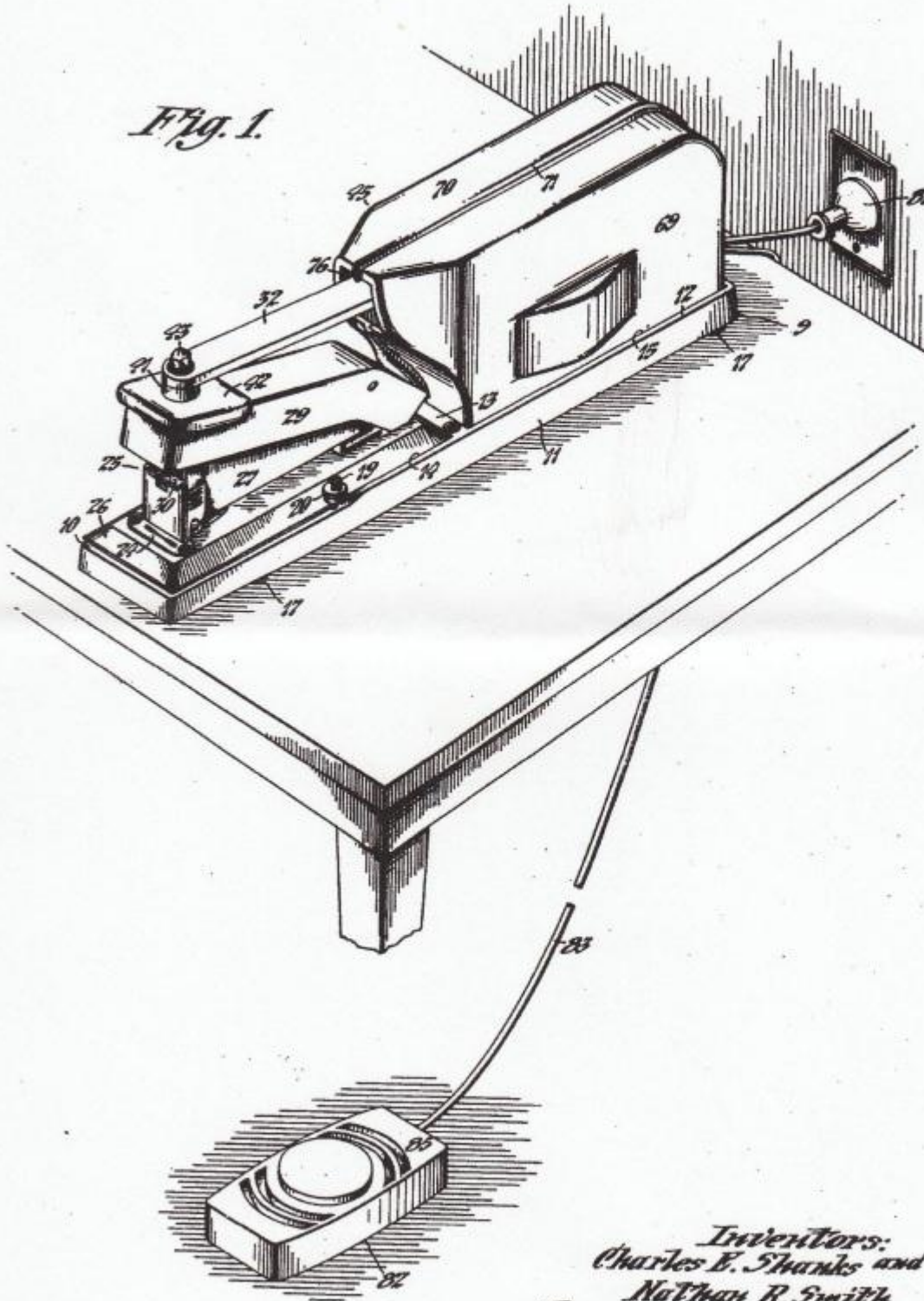

Inventors:
Charles E. Shanks and
Nathan R. Smith
By *Pennington & Pennington*
Attorneys.

The Bostomatic was advertised by Bostitch in 1956.

Bostitch was a very strong fastener producer and had many models of fasteners on the market. They have continually made manual and electric staplers throughout the years. The workmanship and quality of the Bostitch products have always withstood the test of time.



BOSTITCH BOSTOMATIC Stapler

A new electro-magnetic stapler which operates automatically when papers are inserted against featherweight touch switch. 4¼" throat. Will staple up to thirty-two sheets of 16 lb. bond. Single trip, current releases automatically when staple is driven. May be mechanically tripped, if desired.

Bostitch

This is a mid to late 1950's example of the Bostitch Bostomatic Model B5E3J Electric Stapler. This electric example was a 110 volt, 15 amps at 60 cycle system. Safe to say, this electric stapler is hard to find, probably because when they broke, most owners would discard them rather than take a chance of shorting out their home or office.

With little effort, the Bostitch Stapler could easily be removed from the electrical portion of the device and used in a manual manner.

The Bostitch Stapler held a patent number of 2150332 issued on March 14, 1939. The Inventor was Arthur H. Maynard who was well known as one of the most knowledgeable fastener inventors in the industry. What made this stapler ideal was that it uses standard size staples. Standard staple could be found everywhere from your local 5 and Dime to Sear and Roebucks.



E. H. HOTCHKISS COMPANY

An early example of electric staplers comes from Roy E. Peterson who was with the Hotchkiss Stapler Company for years and responsible for many of their fasteners and designs.

This patent was applied for on October 28, 1929 with an approval date of May 26, 1931.

Peterson acknowledges that operating a foot operated or hand operated stapler numerous times during the day, may be exceedingly tiring to the user.

It is not known whether this fastener was ever produced. None have surfaced to date, but the stapler is a Model 1A patented December 10, 1918 and are still found today in good working order.

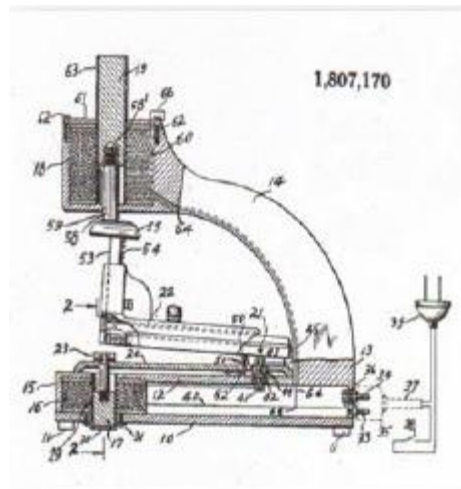

This example, invented by Francis J. Taylor, Jr. uses the Hotchkiss Model 122 as its staple driver. Taylor filed for his patent on August 27, 1948. The patent was approved on March 14, 1950.

Note the similarities to the Boston Wire Stitcher Model 4.

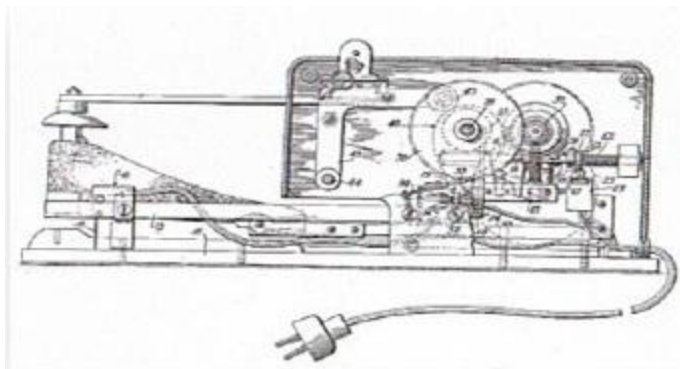

MARKWELL MANUFACTURING COMPANY, INC.

Only after a careful review of my own data base did I find that Markwell had developed an electric stapler in the early 1950s.



**An early Markwell development:
Electric desk stapler, 1951
Incorporating the RF Staplemaster
front-loading desk stapler**

As indicated this electric stapler used the RF model as its fastener and worked under the same principles as the other electric staplers, an actuator.

STAPLEX COMPANY

James J. Oussani's invention is a fastener that many collectors will recognize. Patent Number 2,403,947 was applied for on May 19, 1944 . This patent was approved on July 16, 1946.

As a foot note, his patent attorney was Nooster Davis. The same attorney used for years by the Hotchkiss Stapler Company and by Gertrude Hotchkiss Heyn after she sold the company.

The stapler boasted an automatic trigger in which the inserted paper would activate the stapler.

This patent was procured by Staplex Company Brooklyn, New York and was produced by them in 1949. Staplex claims to hold the first patents issued for an electric stapler which has yet to be substantiated. Regardless, Staplex has been producing many electric staplers throughout the years and is certainly a leader in this field.

This model was more commercially successful than other electric staplers as evident by its availability today. They can be found at flea markets and antique shops and eBay, but then, who's looking.



July 16, 1946.

J. J. OUSSANI

2,403,947

ELECTRIC FASTENER DRIVING MACHINE

Filed May 19, 1944

2 Sheets—Sheet 1

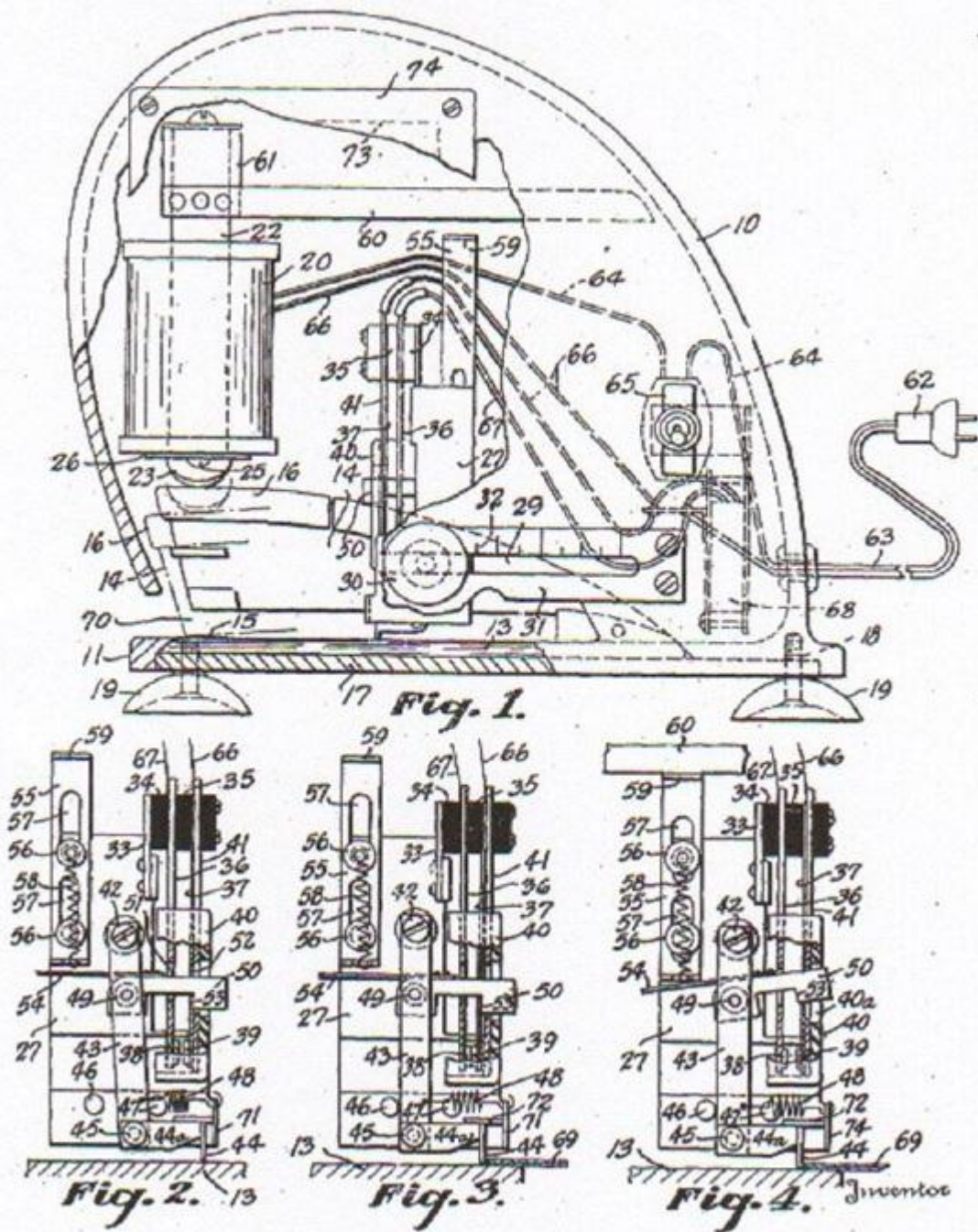

James J. Oussani
384 Hoover & Davis
Attorney

If you do any stapling
... you need **Staplex!**

**AUTOMATIC
ELECTRIC
STAPLING ... AT ITS
MONEY SAVING BEST!**

A Necessity
IN MODERN BUSINESS!

Staplex
TRADE MARK



SWINGLINE

Swingline does not appear to have had interest in the electric stapler until much later. To date, the earliest example found appears to be the Swingline Model 66A.

This fastener was made using the same technology as their competitors.



YOUR SWINGLINE 66A operates on 115 V. AC—60 cycle current only. This machine is factory lubricated and requires no further lubrication. THE SWINGLINE 66A will operate with all "standard" size staples but for best results and guaranteed performance, use only Swingline 66 Electric Staples. Each strip contains 210 staples.

Swingline 66 ELECTRIC STAPLES

ECONOMY PACKAGE SAVES UP TO 31% BREAKAGE OF STAPLES

These staples are made of Ruthenium wire to our specifications and will assure maximum penetration and perfect operation. They are clear pointed and rust resistant. Standard size.

WARRANTY

The exclusive use of Swingline 66 Electric standard staples will automatically guarantee the normal life of electric machine against defective materials or workmanship for a period of 90 days from date of purchase. Should improper staples be used or machine otherwise abused, we will make only a nominal charge for replacement parts, a small service charge, plus postage and insurance.

SWINGLINE, Inc. 25-26 2875th Avenue Long Beach 51y. C. N. S.

OPERATING INSTRUCTIONS

Swingline 66A AUTOMATIC ELECTRIC STAPLER

Swingline

It has been said, the Swingline Electric Stapler was introduced in 1956. Yet, where was it, what did it look like and why aren't they in any collections.

Turns out, perhaps they are in collections. The Swingline Model 66P appears to be an earlier version of the 66A which was introduced around 1958 to 1959. That stapler was sold in greater numbers and in the finest tradition of Swingline, was well made, which equated to a longer life.

Unlike the Bostitch, Swingline designed their electric stapler where the stapler could not be removed from the electrical portion of the device therefore, could not be used in a manual manner. This could be, at least in part, explained why there aren't many around. When they broke, they were discarded.

The Swingline Electric Stapler was a 110 volt, 15 amps at 50-60 cycle system

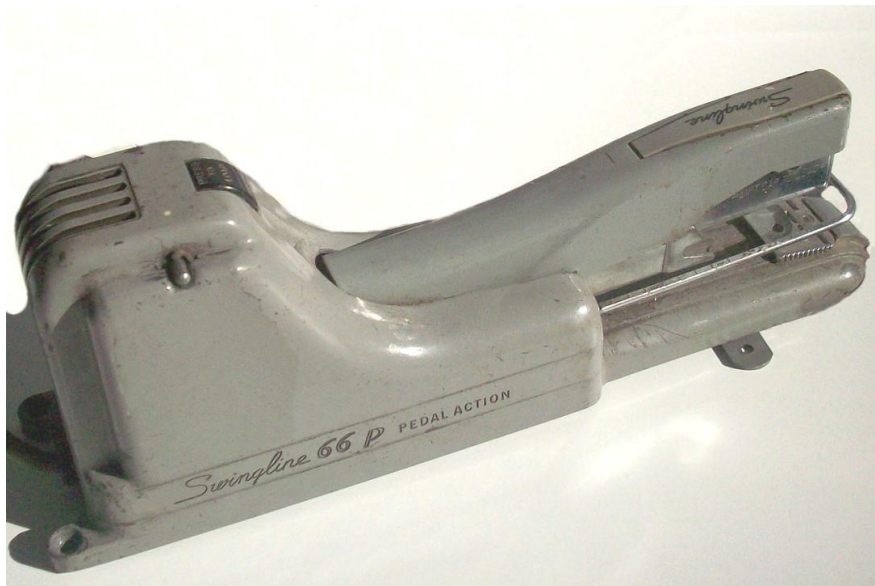

And the story continues. There is still much to be learned. There are many fasteners to be discovered and researched. For now, it is safe to say, staplers and especially, electric staplers have been with us for a longer period of time than what we believed.

March 31, 1959

S. BOYLE ET AL

2,879,510

ELECTRIC FASTENER DRIVING MACHINES

Filed Nov. 30, 1956

3 Sheets-Sheet 1

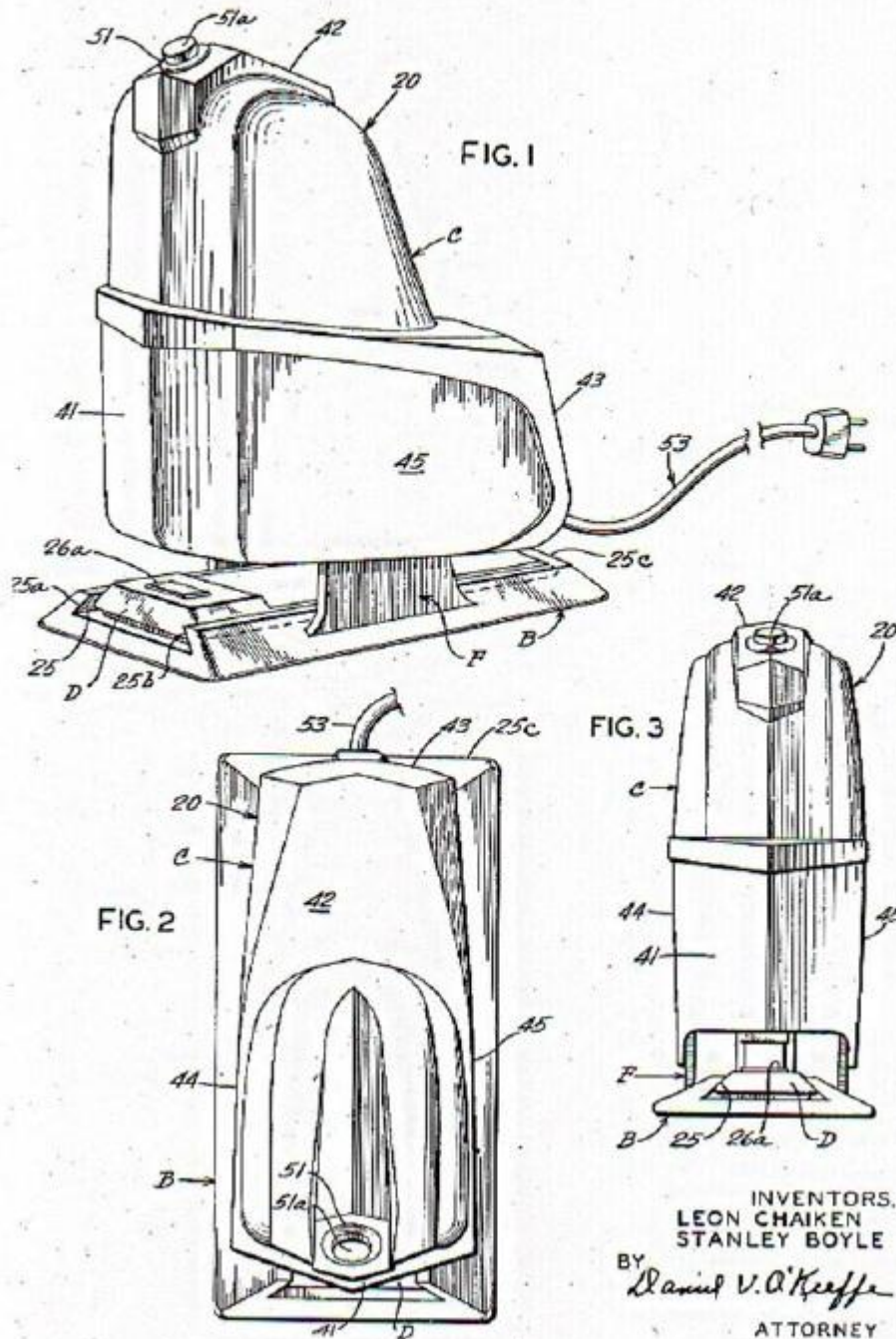

Acco claims they produced the first electric stapler for the purpose of use in the office and on desk. This ad has to be from the 1970's, but who would argue the point, it is just advertising.

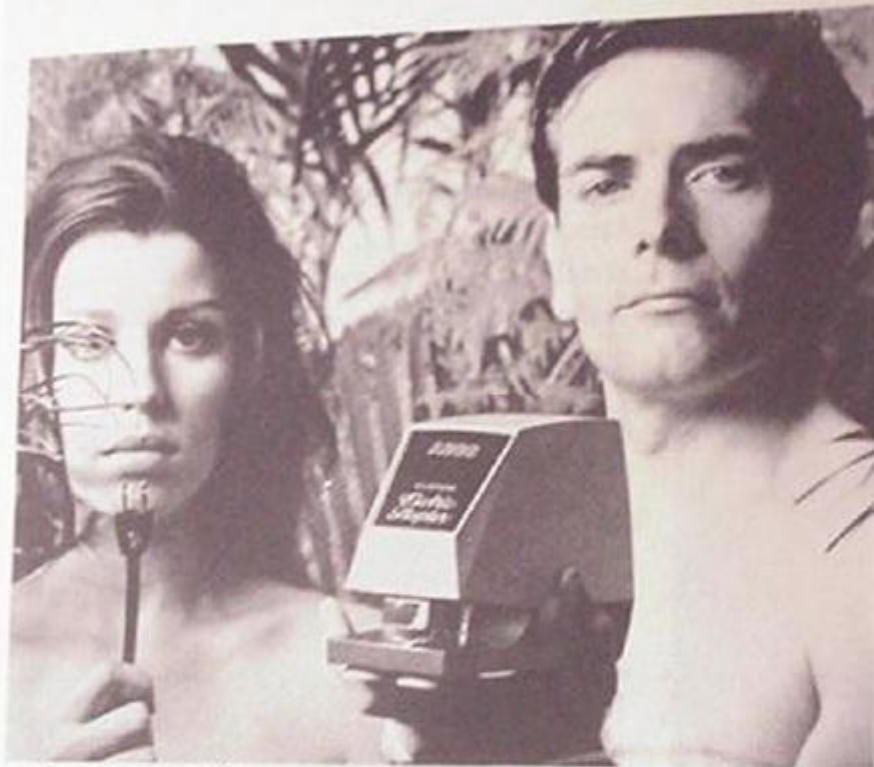

**The world's first
electric stapler
for desk
or counter.**

This classically styled, superbly functional Acco Electric Stapler is the first ever designed to be seen and used on desks or counters in office, store and home. It belongs! Features automatic "pop-out" reloading plus instant margin control: uses standard staples. Ask for a demonstration; the results can be electrifying!

ACC0 5130 N. Northland Highway, Chicago, Illinois 60630; Gary International, Chicago, Illinois; 9800
Lorain, Gaylord, Kent, England; Newco, Inc., Newark, New Jersey; Divisions of Gary Industries, Inc.

